

APPLICATION

Galvanised anchor post 70x70x500 galva

DESCRIPTION

anneau d'ancrage inox stainless steel anchor

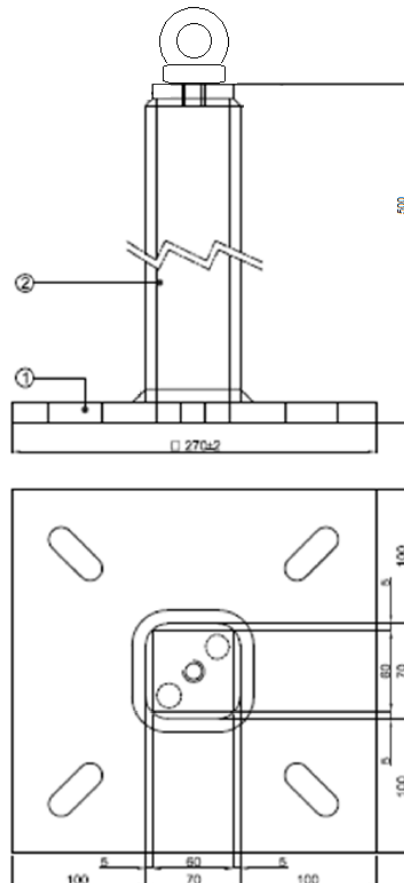

DETAIL ①

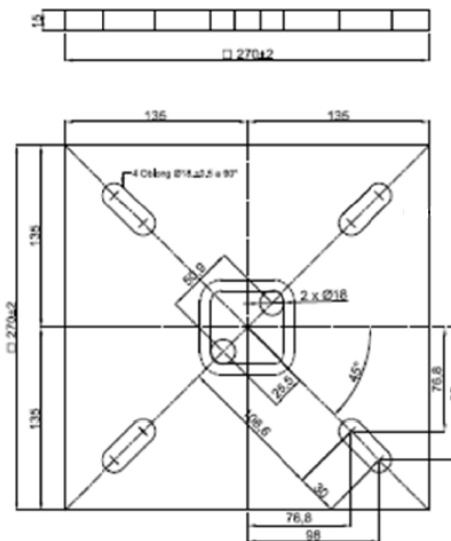

DETAIL ②

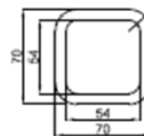

TECHNICAL CHARACTERISTICS

- Material: galvanised steel
- Net weight : 10.6kg
- 1 : base galvanised steel 270x270
- 2 : galvanised tube 70x70x500
- Stainless steel anchor ring

APPLICABLE STANDARDS

- EN 795A

COMPOSANTS PRINCIPAUX

Code	Description	EAN Code	Weight (incl. packaging)	Packaging size
66968	Potelet d'ancrage 70x70x500	3600230669687	10.6kg	270x270x500 mm